

# ARIA COMPRESSA CE

## COMPRESSED AIR / NITROGEN RECEIVERS (DIR. 2009/105/CE)



CE

WORKING TEMPERATURE	
Tmax	
	-10/+100 °C

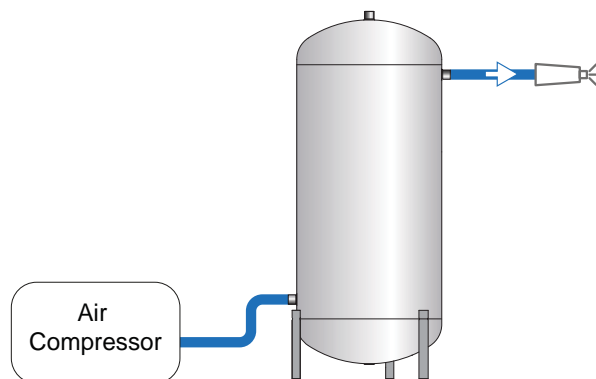

### TECHNICAL DESCRIPTION

Compressed air receivers allows to extract more air that the quantity produced by compressor, this without causing an under-pressure in the unit.

Built in mild steel, either painted, galvanized and painted with food internal coating Polywarm® according to D.M. nr. 174 dated 06/04/2004.

### APPLICATION

Storage and distribution of compressed air.

### MATERIAL

- Painted mild steel (standard colour RAL 5002-

Blue)

Other colours on demand:

- RAL 5015- Light Blue
- RAL 3000- Red
- RAL 1021- Yellow
- Galvanized mild steel
- Painted mild steel version with internal food coating (Polywarm®)

### DOCUMENTS ATTACHED

- CE certification- User Instructions

### CERTIFICATIONS

Compressed air receivers are produced according to European Directive 87/404/CE for items with a "volume x pressure" under than 10.000 Bar • Liter. These tanks are marked CE under the monitoring of an external control agency.

- Liquid in pressure: air
- Liquid group: 2
- Maximum working pressure: (See tab)
- Temperature: -10/+100°C

GALVANIZED / PAINTED



(\*) Other colours on demand: RAL 5015 Light Blue / RAL 3000 Red / RAL 1021 Yellow

2009/105/CE		VERTICAL COMPRESSED AIR RECEIVER	
Model	Working Pressure	GALVANIZED	PAINTED - RAL 5002 BLUE (*)
	[Bar]	Art. Nr.	Art. Nr.
100	<b>11</b>	3053171990001	3053172240001
200		3053171990022	3053172240022
270		3053171990003	3053172240003
500		3053171990004	3053172240004
710		3053171990025	3053172240025
900		3053171990026	3053172240026
270	<b>15</b>	3053171990034	3053172240034
500		3053171990014	3053172240014

PAINTED WITH FOOD INTERNAL COATING \*\*



(\*) Other colours on demand: RAL 5015 Light Blue / RAL 3000 Red / RAL 1021 Yellow

2009/105/CE	
Model	Working Pressure
	[Bar]
100	<b>11</b>
200	
270	
500	
710	
900	
270	<b>15</b>
500	

# ARIA COMPRESSA CE

## COMPRESSED AIR / NITROGEN RECEIVERS (DIR. 2009/105/CE)

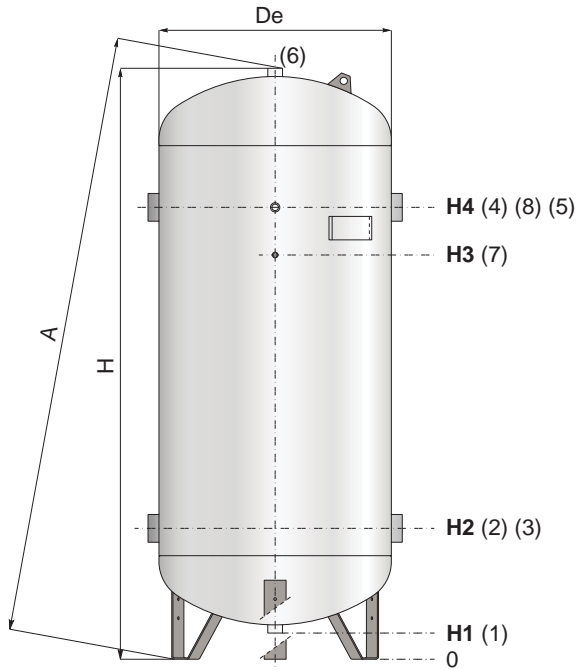

1	Drain
2-3	Air entry
4-5	Use
6	Safety Valve
7-8	Instrumentation

Model	Working Pressure	De	H	A	H1	H2	H3	H4	Connections Gas F			
	[bar]								[mm]			
100	<b>11</b>	400	1105	1125	145	380	790	870	2"	1"	3/8"	3/8"
200		450	1470	1490	145	385	1125	1225	2"	1"	3/8"	3/8"
270		500	1760	1780	150	410	1330	1450	2"	1"	3/8"	3/8"
500		650	1850	1870	170	485	1285	1485	2"	2"	3/8"	3/4"
710		790	1900	1930	135	585	1360	1460	2"	2"	3/8"	3/4"
900		790	2130	2160	145	490	1390	1590	2"	2"	3/8"	3/4"
270	<b>15</b>	500	1760	1780	150	410	1330	1450	2"	1"	3/8"	3/8"
500		650	1850	1870	170	485	1285	1485	2"	2"	3/8"	3/4"

### EXAMPLE OF COMPRESSED AIR RECEIVER PLANT

In compressed air production and distribution systems, tanks are used in production plants for the following functions:

- to store compressed air in order to use it when needed
- to ensure network air flow and constant pressure by limiting interventions to adjust the flow;
- to favour the separation of condensation through the release of the flow coming from the compressor in the bottom of the tank and connecting delivery in the upper.

Furthermore, the tanks are located near uses characterised by highly variable air requirements in order to limit pressure fluctuations along the distribution lines.

Optimum tank volume in a production system depends on the type of compressor,

environmental conditions of operation and type of use.

In systems characterised by max operating pressure of 10 bar and flow rates from 1 to 100 Nm<sup>3</sup>/min, tank capacity is calculated, as a first approximation, with the following relationship:

$$V = 0.2 \text{ to } 0.6 Q$$

V = theoretical volume of the tank in m<sup>3</sup>

Q = intake flow rate from the compressor in m<sup>3</sup>/min

0.2 = coefficient for large plants

0.6 = coefficient for small plants

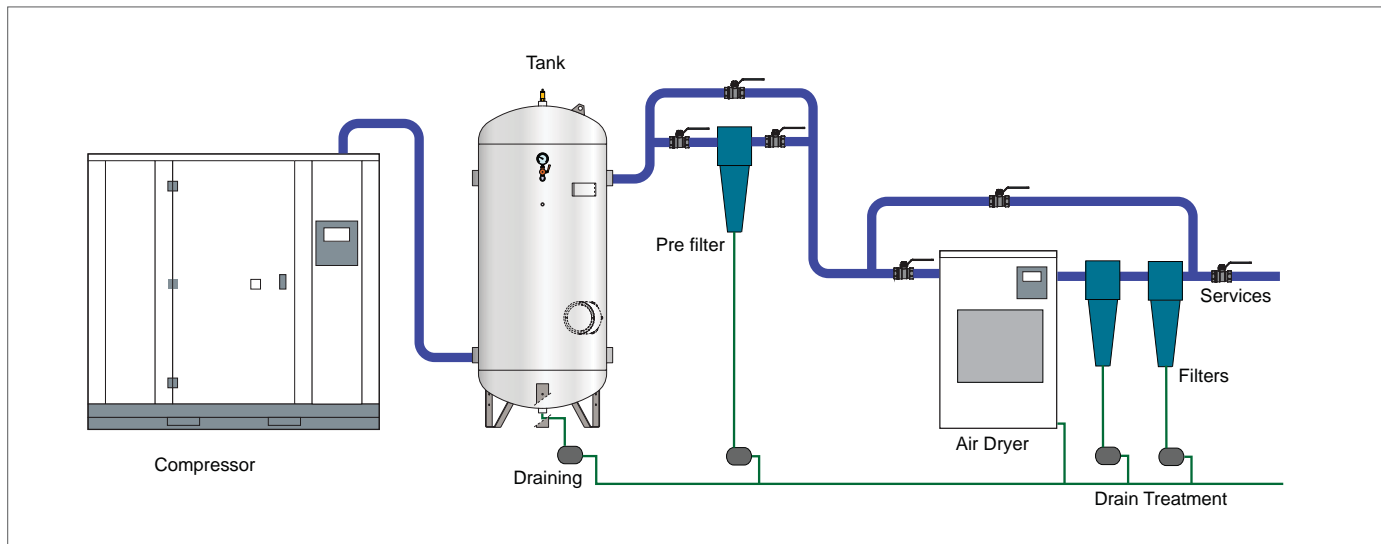

COMPRESSED AIR RECEIVERS